

D20-1524-W1 Young's Experiment Set with Laser Pointer

(Diffraction & Interference of Light Experiments)

And

D20-1524-X0 Young's Experiment Set without Laser Pointer & Diffraction Slit

(Diffraction & Interference of Light Experiments)

Instruction Manual

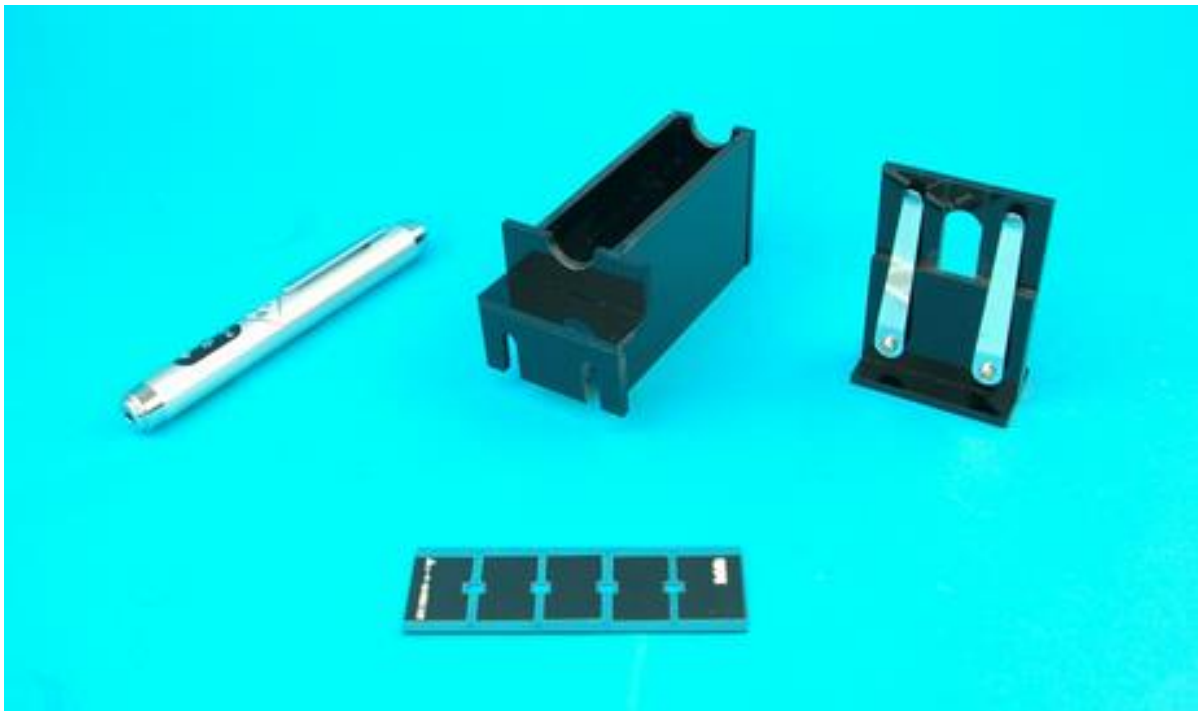

NaRiKa Corporation

<http://global.narika.jp/>

Precautions



You should not directly look into the laser rays when conducting experiments with laser rays and this product. Laser rays may damage your eyes.



You should not use "Slit for Light Diffraction Grating" without shield sticker which protect your eyes from laser rays, when you use the laser pointer. You should put the shield sticker on the product in order to avoid the reflection of Laser rays into your eyes before starting use of this product.



You should not disassemble this product. This product might stop working and warranty will be void.



Do not let students to conduct experiments without the presence of teacher or trainer. Teacher or trainer must instruct students about the safe ways of conducting experiments with this product before conducting experiments.



Be careful when handling the slit because it is made from glass. In the case that the slit is broken, do not touch bits of glass by your hands. Especially, do not let students to touch them.



If the slit breaks, stop experiments immediately as it can be dangerous for students or teachers, because they can cut themselves by the broken parts of the slit.



Keep the product dry and away from water. If exposed to water this product can be damaged and not work properly.

Thank you very much for purchasing this product. You should read and understand the precaution in advance before you start conducting experiments. Please store this instruction manual after reading somewhere close, so that you can refer to it easily if needed.

Introduction

This product "Young's Experiment Set" is for the experiment of Light interference and diffraction using a laser pointer.

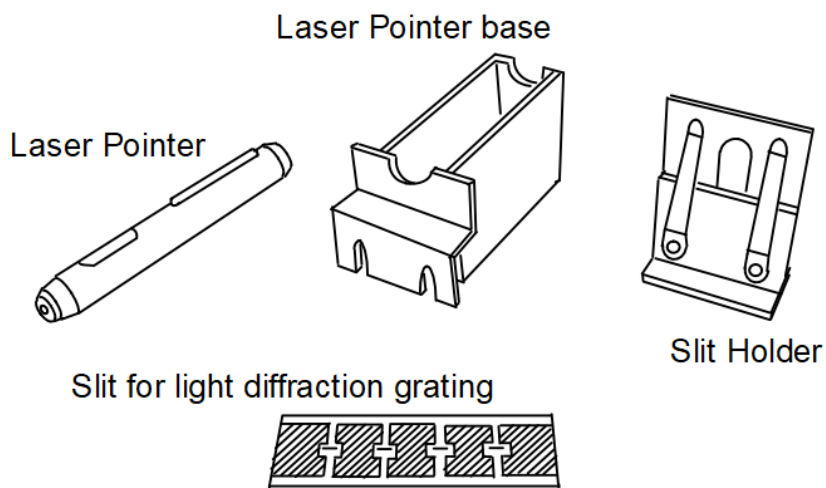

Items	Individual Cat. No.	Amount	D20-1524-W1	D20-1524-X0
Slit for light diffraction grating	D20-1842-01	1 pc	✓	-
Laser Pointer base	-	1 unit	✓	✓
Slit holder	-	1 unit	✓	✓
Laser Pointer TLP-3200	D20-1162	1 unit	✓	-

Slit for Light Diffraction Grating D20-1842

"Slit for Light Diffraction Grating" is a component of this set. "Slit for Light Diffraction Grating" is the highest quality grade slit that is suitable for Young's experiment. The single slit and double slit and diffraction gratings are on one plate of glass.

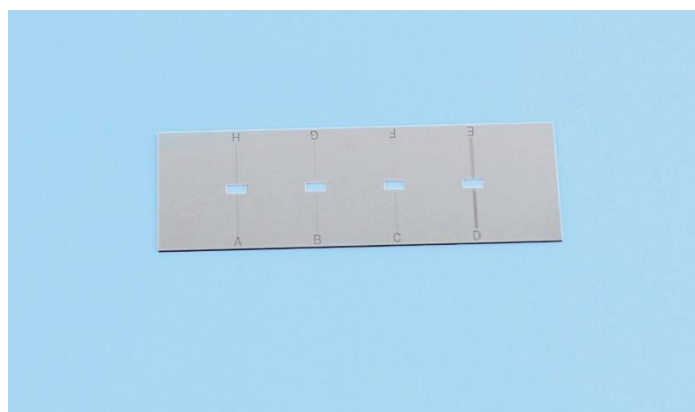

D20-1842 Slit for Light Diffraction Grating

Specification

- Size: 76 x 26mm, Amount: 1 pc
- Slit: Single, Double slit (6 kinds), Diffraction Grating (2 kinds) (See Table 1).
- Shield Sticker: 1 sheet
- Four small square holes in the middle of the glass are for easier navigation of laser beam into the slit before starting observation.

Table 1. Number of Lines, width and gap of Slit for Light Diffraction Grating.

	A	B	C	D	E	F	G	H
Number of lines	2	2	2	30	10	1	1	1
Width (mm)	0.02	0.02	0.02	0.01	0.02	0.01	0.02	0.05
Gap (mm)	0.04*	0.07*	0.22*	0.02*	0.06*	-	-	

*The gap is measured from the middle of one slit to the middle of another slit.

Preparation for Experiment

You should attach the enclosed shield sticker on "Slit for Light Diffraction Grating" for protection of eyes to avoid damaging them by reflected laser ray. The slit and the enclosed sticker in the product comes separately like on following Fig. 1 and Fig. 2. As the surface condition of the slit is same as a mirror, it can be dangerous to use without the shield sticker.

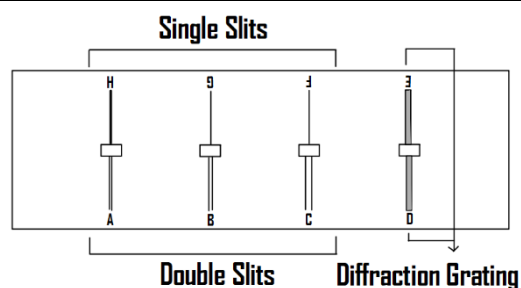

Fig. 1 Slit for Light Diffraction Grating

In addition, the surface of the slit can be easily removed or damaged by scratching, because of its sensitive thin coating. Therefore, the shield sticker is needed on the surface of coating side as a protection.



Fig. 2 Shield Sticker Sheet

Use as a reference process to stick the shield stickers on the Slit for Light Diffraction Grating (Fig. 3). Advice, you should start sticking the shield sticker on the face side from the edge end of the slit.

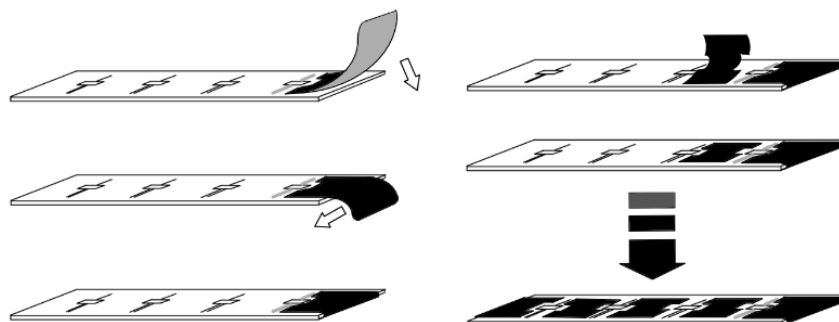

Fig. 3 Steps to attach Shield Sticker on the slit glass

Laser Pointer base & Slit holder D20-1524-X0

Connect the slit holder and the laser pointer base using screws and nuts together (see Fig. 4). You should not need tools to do it.

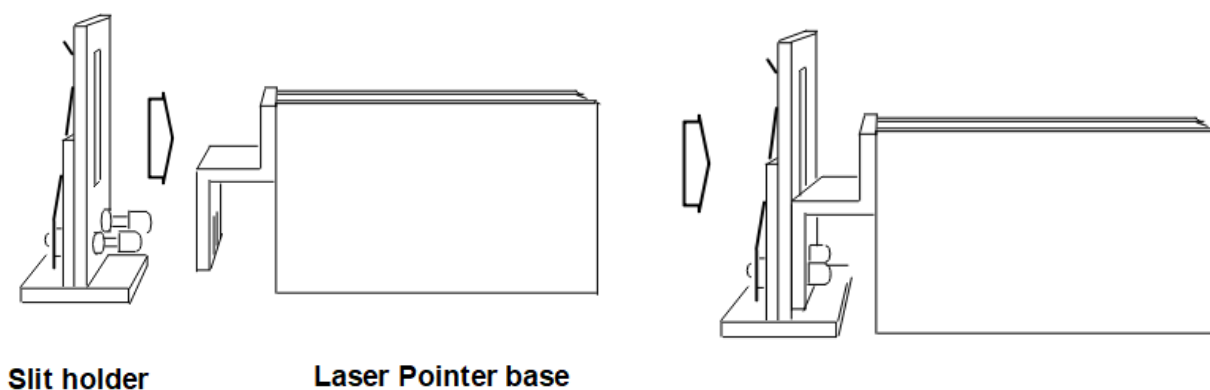

Fig. 4 Laser Pointer base & Slit holder

Laser Pointer TLP-3200 D20-1162

Laser pointer TLP-3200 is included in D20-1524-W1, but not included in D20-1524-X0. It is possible to use another type of a laser pointer. In that case, the size up to 14mm diameter of laser pointer is available to fit on the base.

Laser pointer TLP-3200 can be placed on the base as shown on Fig. 5. Place the laser pointer simply on the base. The base does not have any function other than holding the laser pointer.

Specification of Laser pointer TLP-3200

- Wavelength: 650 ~ 660nm (red)
- Output: Less than 1mW (Class 2 laser)
- Diameter of its beam: $\phi 8 \sim 10$ mm at 5m distance
- Size: $\phi 13 \times 110$ mm
- Power Supply: N type dry cell battery x 2 pcs

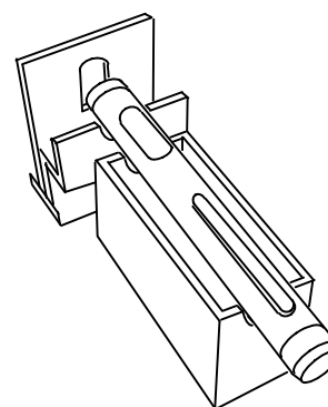

Fig. 5 Laser Pointer placed on the base

Experiment Procedure

1. Set the slit into the slit holder of the completed equipment as shown on Fig. 6. and put the laser pointer on its base (Fig. 7). Then, adjust position of the beam axis and the slit by turning on the laser pointer and adjusting beam emitted by sliding the slit on the holder as needed.

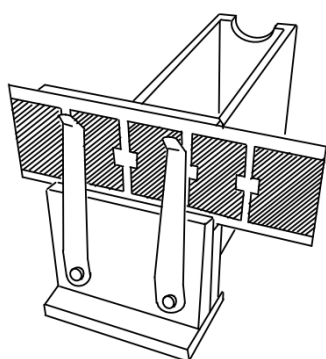

Fig. 6 The slit and holder

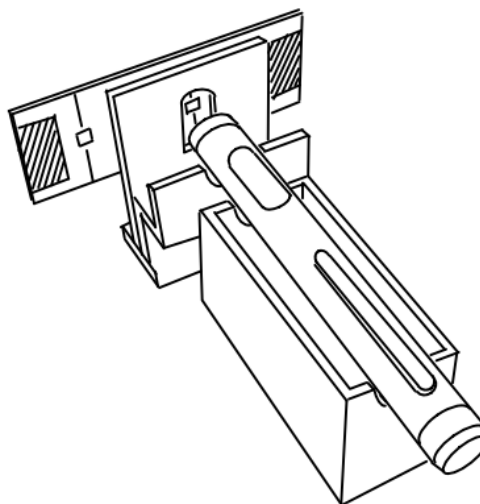
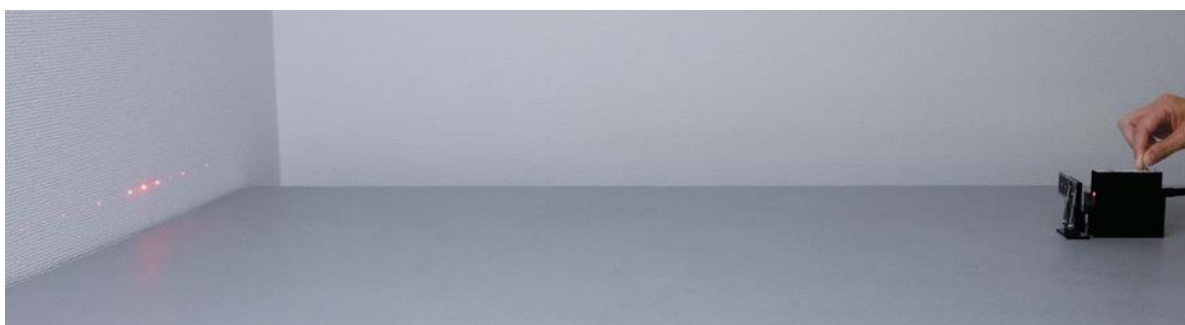

Fig. 7 The completed set

[Cautions and warnings]

Pay attention to reflection of the beam! Do not look at the reflection of the beam to avoid eye damage.

2. Place the completed set 1.5 to 3.0m away from a wall or a screen. Project the diffraction and interference fringe on the wall (screen). Observe the pattern of the beam on the wall, measure the interval distance between the line of the beam.



[Tips and tricks]

NARIKA recommends dark room for experiments with this set. Especially, because the laser used is not very strong, thus projected diffraction and interference of single and double slit might not be very clear, the use of dark room will create better conditions for observation and measurement. Use of white color for screen or projection on white wall is recommended for better visibility as well.

Sample data

[Investigation of the wavelength of light source using known data of slit width]

Calculated wavelength from sample data is shown in Table 2. In the investigation, laser pointer used was Green Laser pointer (D20-1173-W0) which has wavelength of 532nm. The range of the calculated wavelength λ is from 493.3 to 542.5nm, which is good accuracy.

Table 2. Sample data

Slit	Interval distance of slit d (mm)	Distance to Screen L (mm)	Interval of Interference fringe ΔX (mm)	Wavelength λ (nm)
A (Double slit)	0.04 (Width 0.02)	2,000	25	500.0
		3,000	37	493.3
B (Double slit)	0.07 (Width 0.02)	2,000	15.5	542.5
		3,000	23	536.7
C (Double slit)	0.22 (Width 0.02)	2,000	5	550.0
		3,000	7	513.3
D (Diffraction grating)	0.02 0.01 x 30 lines	2,000	52	520.0
		3,000	78	520.0
E (Diffraction grating)	0.06 0.02 x 30 lines	2,000	17.5	525.0
		3,000	26	520.0

$$\lambda = \frac{d\Delta X}{L}$$

d = Width of slit

ΔX = Interval of interference fringe

L = Distance from screen



NaRiKa Corporation

<http://global.narika.jp/>